



**PRODUCT WEAPON CATEGORY**  
**DIFFICULTY LEVEL**  
**REVISION**  
**TOOLS REQUIRED**

**PRS™ (Gen II)**  
**AR15/M16 or AR10/SR25**  
**Installation**  
**Easy**  
**11.19.07**  
**Flat-Head Screw Driver, 1/8" Hex Key**



## Installation of the PRS™ Stock for the AR15/M16 or AR10/SR25

The PRS™ mounts to rifles using the *M16 Rifle Receiver Extension (Buffer Tube)* without *M16A2 spacer*. All mounting hardware is included. Only a trained and qualified armorer/gunsmith should perform installation of this equipment. Please refer to US ARMY TM 9-1005-319-23&P on armorer guidelines for original equipment removal. *NOTICE: Magpul Industries shall not be responsible for injury, death or damage to property resulting from improper installation, misuse, or illegal use of this product.*



**WARNING: Observe safe firearm handling practices at all times. Failure to do so may result in grievous bodily injury or death.**

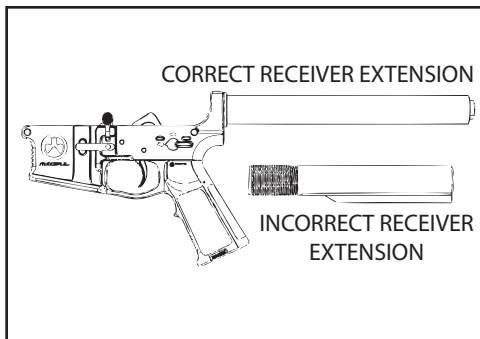

### STEP 1 - Stock Removal

**WARNING: BEFORE BEGINNING, MAKE SURE THE WEAPON IS UNLOADED AND THE SAFETY ENGAGED.** Remove upper receiver from the weapon. Remove original stock using care to prevent losing the *Takedown Pin Spring* and *Detent*. Make sure an *M16 Rifle Receiver Extension*, *Rifle Buffer*, and *Rifle Action Spring* are installed. If not, replace them with the correct parts to armorer specification.

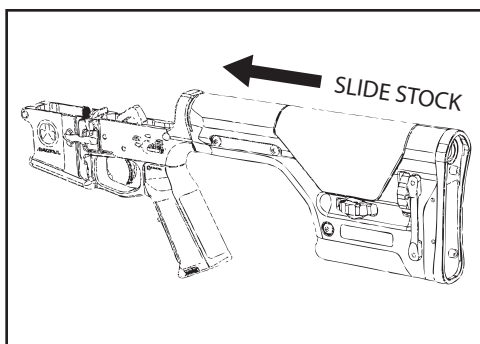

### STEP 2 - PRS™ Mounting

Detach PRS™ *Rubber Butt-Pad* by removing screws with a 1/8" hex key. Verify the *Takedown Pin Spring* and *Detent* are placed properly in the *Lower Receiver*. Slide the PRS™ stock over the *M16 Rifle Receiver Extension*. Make sure the *Takedown Pin Spring* does not bind when seating the stock. If the stock does not slide easily into place, loosen both screws on the *front Footman's Loop (Sling Mount)* using a 1/8" hex key.

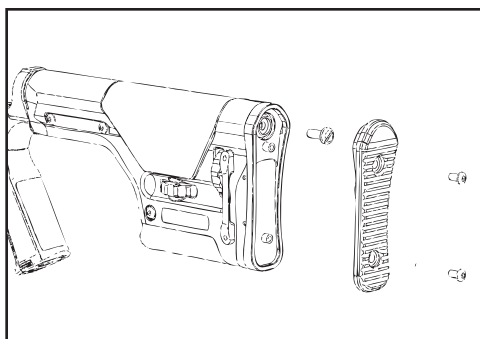

### STEP 3 - Retaining Screw Installation

Using a flat-blade screwdriver, secure the PRS™ stock with the provided *Vented Mounting Screw* and tighten until hand tight. **DO NOT** use any other screw to mount the PRS™ as it may affect weapon cycling or damage the stock. Tighten the *front Footman's Loop Screws* if they were previously loosened. Using a 1/8" hex key, reinstall *Rubber Butt-Pad*. Always test fire your weapon prior to use in operational environments!